

# SPICER® AXLE

## MAINTENANCE MANUAL

MODEL



FRONT AND REAR  
CARRIER TYPE

# 60

---

SPICER AXLE DIVISION



DANA CORPORATION

FORT WAYNE, INDIANA

Part 1 of 2 – Dana 60 Front Axle

## INDEX

LUBRICATION .....	3
IDENTIFICATION OF SERVICE TOOLS .....	4
AXLE IDENTIFICATION .....	5
FRONT AXLES — WHEEL ENDS	
Closed Knuckle Design (Hub & Drum) .....	6
Spring Loaded King Pin Design (Hub & Rotor) .....	14
REAR AXLES — WHEEL ENDS, SEMI-FLOAT DESIGN	
Unit Wheel Bearing .....	20
(Lubricated with Hypoid Gear Lube)	
Unit Wheel Bearing .....	22
(Lubricated with Grease)	
Shaft Riding Bearing .....	27
(Lubricated with Hypoid Gear Lube)	
REAR AXLES — WHEEL ENDS, FULL-FLOAT DESIGN .....	32
CARRIER SECTION .....	34

### IMPORTANT SAFETY NOTICE

Proper service and repair is important to the safe, reliable operation of all - (Motor Vehicles) or (driving axles whether they be front or rear). The service procedures recommended and described in this service manual are effective methods for performing service operations. Some of these service operations require the use of tools specially designed for the purpose. The special tool should be used when and as recommended.

It is impossible to know, evaluate, and advise the service trade of all conceivable ways in which service might be done or the possible hazardous consequences of each way.

Accordingly, anyone who uses a service procedure or tool which is not recommended, must first satisfy himself thoroughly that neither his safety nor vehicle safety will be jeopardized by the service methods he selects.

### NOTE

Throughout this manual, reference is made to certain tool numbers whenever special tools are required. These numbers are numbers of Miller Special Tools, 32615 Park Lane, Garden City, Michigan 48135.

# LUBRICATION

It is not our intent to recommend any particular brand or make of lubricant for the Spicer hypoid axles. However, an S.A.E. 90 or 80W-90 multi-purpose gear lubricant meeting MIL. Spec. L-2105-C, and suitable for A.P.I. Service Classification GL-5, is suggested as a minimum requirement. It must provide necessary and suitable load-carrying characteristics to prevent scoring and wear, good stability in storage and service, and give good resistance to corrosion. Suppliers should assure these characteristics and be responsible for the quality and satisfactory performance of their product.

## WHEEL BEARING LUBRICATION

Wheel bearings are lubricated by one of two different methods. One is to pack the wheel bearing with grease; while the other method is to lubricate the wheel bearing with the hypoid gear lube in the housing.

For grease packing, it is recommended that a number 2 consistency, lithium base 12 hydroxy stearate grease containing an E.P. additive be used. Such a lubricant would pass a load-carrying test at 40 pounds (18.5 Kg.) minimum with base oil pour point at -10°F (-23°C) maximum.

For wheel bearings which depend on lubrication from the hypoid gear lube in the axle housing, it is recommended that an S.A.E. 80W-90 multi-purpose gear lube meeting MIL. Spec. L-2105-C be used.

### NOTE

We suggest that wheel bearing lubricants selected for use with Disc Brake applications, in addition to the E.P. properties expressed in this manual, should be compatible with elevated temperatures, i.e., high temperature lubricant. For specified wheel bearing lubricant, refer to Vehicle Service Manual.

## CLOSED WHEEL END STEERING KNUCKLE LUBRICATION

The closed steering knuckle requires lubrication from a source other than the gear carrier assembly. Inboard tube seals contain the hypoid gear lube in the housing to provide adequate lubricant level for the gears, bearings, etc. This then requires an additional lubricant level to be maintained outboard, in each steering knuckle, which can be observed by removing fill plugs on each knuckle. Adequate level would be to the bottom of the fill plug hole, when vehicle is observed to be in a normal horizontal position.

Recommended lubricant is an S.A.E. 140 grade, multi-purpose gear lubricant meeting the MIL-L-2105C specification.

### IMPORTANT

As special equipment, limited slip differentials are provided in many vehicles, the freedom from "chatter" is a function of the lubricant used and cannot be covered in the above specification. In some applications, a special limited slip differential lubricant may be required. If required, these special lubricants are normally available through the original equipment manufacturer.

## COLD WEATHER OPERATION

If the vehicle is operated below 0°F. (-18°C), it is advisable to use S.A.E. 80 or 80W-90 multi-purpose gear lubricant meeting MIL. Spec. L-2105-C and suitable for A.P.I. Service Classification GL-5.

## SUBMERSION OR DEEP WATER FORDING

If the vehicle is exposed to water deep enough to cover the hubs or wheel bearing retainer plate and oil seal of either the front or rear axles, it is recommended that the wheel ends be disassembled and inspected for water damage and/or contamination daily.

In the event the gear carrier housing should become submerged in water, particularly if over the breathers, it is recommended that the hypoid gear lubricant be drained daily and internal parts be inspected for water damage and/or contamination.

Clean, examine and replace damaged parts, if necessary, prior to assembling the cover housing and refilling with the specified hypoid lubricant.

### NOTE

It is recommended that whenever bearings are removed they are to be replaced with new ones, regardless of mileage.

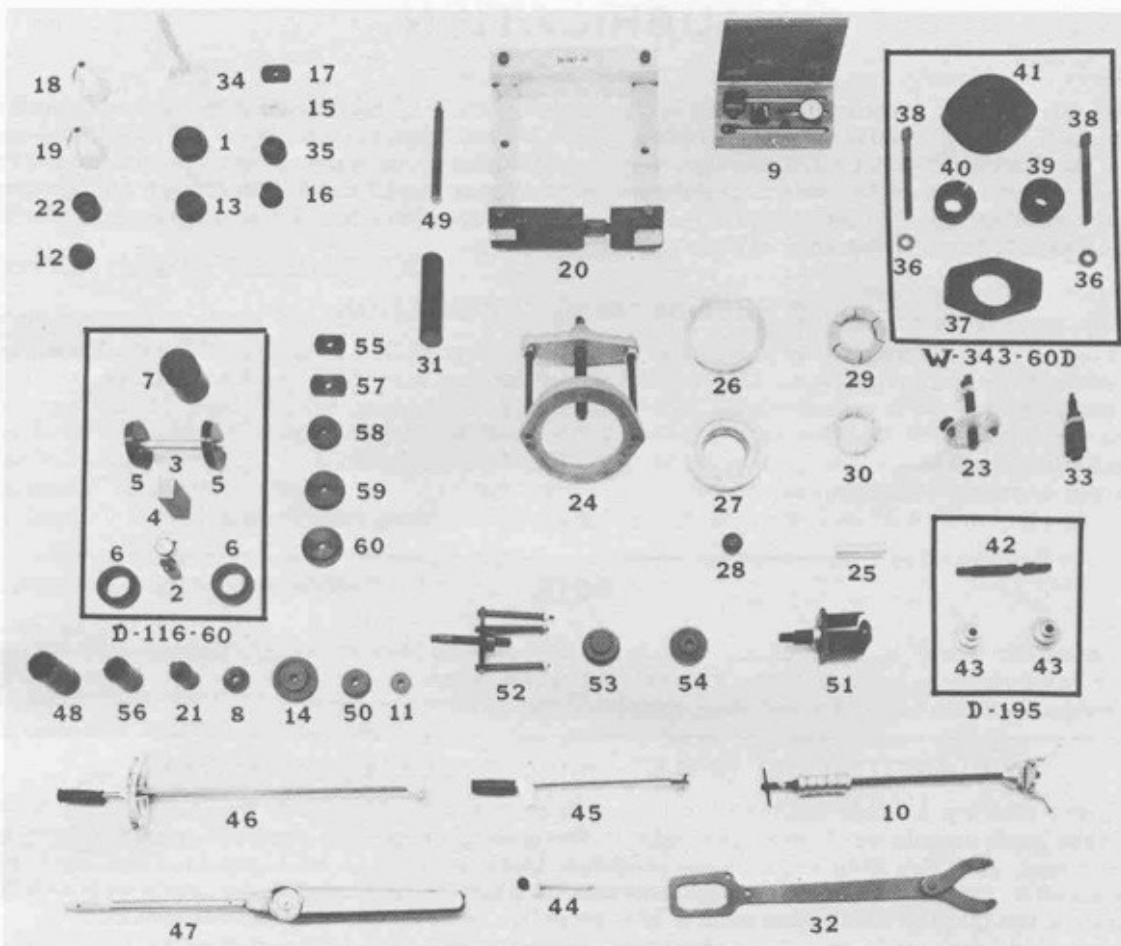


Figure 2

1019-2

The following is a detailed list of all special service tools required to service a Model 60 Front or Rear axle:

ITEM NO.	TOOL NO.	DESCRIPTION
1	D-111	Installer - Rear Pinion Bearing Cup
* 2	D-115	Scooter Gauge
* 3	D-115-3	Arbor
* 4	D-116-1	Pinion Height Block
* 5	D-116-2	Arbor Discs
* 6	D-117	Master Bearing Differential
* 7	D-120	Master Pinion Block
8	D-258	Installer - Front Spindle Needing Bearing
9	D-128	Dial Indicator Set
10	D-131	Puller - Slide Hammer
11	D-141	Installer - Front Spindle Bushing
12	D-142	Installer - King Pin Bearing Cup (Heavy Duty)
13	D-153	Installer - Front Brake Hub Inner Bearing Cup (Reg.)
14	D-155	Installer - Front Brake Hub Grease Seal (Reg. & Heavy Duty)
15	D-158	Remover - Front Pinion Bearing Cup
16	D-161	Installer - Closed Ball Spindle Bushing
17	D-162	Remover - Rear Pinion Bearing Cup
18	D-163	Installer - Pinion Oil Seal (National)
19	D-164	Installer - Pinion Oil Seal (Chicago Rawhide)
20	D-167	Spreader - Differential Carrier
21	D-192	Remover & Installer - Tapered King Pin Upper Ball Joint Pivot Stud
22	D-194	Installer - Steering Knuckle Lower Bearing Seal
23	C-452	Remover - Universal Joint Companion Flange or Yoke
24	DD-914-P	Puller Press
25	DD-914-7	Extension
26	DD-914-8	Reducer Ring
27	DD-914-9	Reducer Ring
28	DD-914-42	Button
29	DD-914-62	Adapter Set - Differential Bearing Cones
30	C-293-37	Adapter Set - Rear Pinion Bearing Cone
31	C-3095-A	Installer - Rear Pinion Bearing Cone

ITEM NO.	TOOL NO.	DESCRIPTION			
32	C-3281	Wrench - Universal Joint Flange or Yoke	49	C-4171	Handle - Universal
33	C-3718	Installer - Universal Joint Flange or Yoke	50	C-4203	Installer - Front Pinion Bearing Cup
34	C-4025-A	Installer - Differential Side Bearings	51	D-232-1	Remover - Bearing
35	C-4026-A	Installer - Axle Shaft Outer Oil Seal	52	D-247	Installer - Press
**36	SP-320	Washers	53	D-248	Installer - Bearing
**37	SP-5017	Adapter Ring	54	D-233	Installer - Oil Seal
**38	SP-5026	Bolts	55	D-255	Cup Remover (Hub & Drum)
**39	SP-5440	Adapter Ring - Installer	56	D-165A	Wheel Bearing Wrench
**40	SP-5441	Adapter Set - Removing	57	D-257	Cup Remover
**41	SP-5443-A	Flange Plate	58	D-254	Installer - Cup (Outer-Hub & Rotor)
***42	D-195-2	Screw	59	D-256	Installer - Cup (Inner-Hub & Rotor)
***43	D-195-1	Installer - Front Axle Differential Inner Oil Seal	60	D-253	Seal Installer
44	D-193	Torque Wrench - 50 Inch Pound	* Pinion Setting Gauge and Master Differential Bearing Kit D-116-60.		
45	C-524-A	Torque Wrench - 100 Foot Pound	** Axle Shaft Bearing Removing and Installing Kit W-343-60D.		
46	C-4053	Torque Wrench - 300 Foot Pound	*** Inner Axle Shaft Seal Installing Kit D-195.		
47	DD-994	Torque Wrench - 1000 Foot Pound	NOTE: Torque Wrenches D-193, C-524-A, C-4053, and DD-994 are optional and can be purchased separately. These torque wrenches are not included in the DW-60 Axle Tool Kit.		
48	C-4170-A	Wrench - Wheel Bearing Lock Nut Adjusting			

## AXLE IDENTIFICATION

All Spicer axles are identified with a manufacturing date and the complete part number stamped in the right hand tube. Also each axle contains a gear ratio tag, and if the axle is equipped with a limited slip differential, it will contain a tag specifying the use of limited slip lubricant.

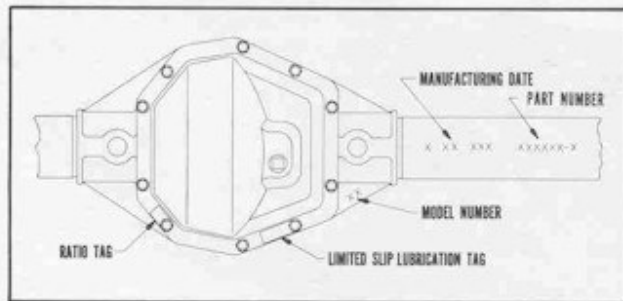


Figure 3

1019-3

In this figure the axle is identified with 1/8" (3.17 mm) high numbers stamped in the tube. For Example: The manufacturing date or build date of the axle is interpreted as follows. The first number is the month, second number is the day of the month, the third number is the year, the letter is the shift, and the last number is the line that built

the axle. The next number is the part (bill of material) number. The six digits reading from left to right is the basic number for identifying the particular axle assembly. The seventh digit following the dash will identify ratio, differential and end yoke options used in the assembly.

### NOTE

In the event there are two build dates, the latter will be the date in which the brake components were assembled. The number stamped next to the manufacturing date is the complete axle assembly part number.

It is recommended that when referring to the axle, obtain the complete part number and build date. To do this, it may be necessary to wipe or scrape off the dirt etc., from the tube.

### NOTE

On front driving axles, the above numbers can be either on the long or short tube.

## AXLE IDENTIFICATION

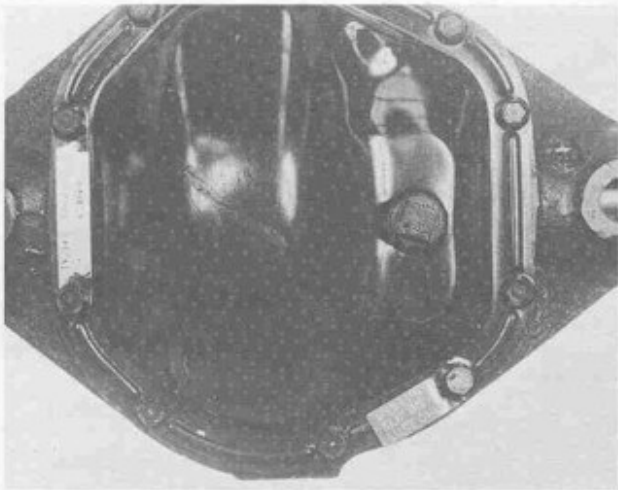


Figure 4

1019-4

The gear ratio tag is located on the left side of the cover plate/or at the bottom left hand side of the cover plate, and is held in place with one or two cover plate screws. This tag gives the tooth combination of the ring and pinion, and also the total gear ratio.

## FRONT AXLE

DISASSEMBLY AND REASSEMBLY OF HUBS, DRUMS, WHEEL BEARINGS, ETC. (CLOSED KNUCKLE DESIGN)

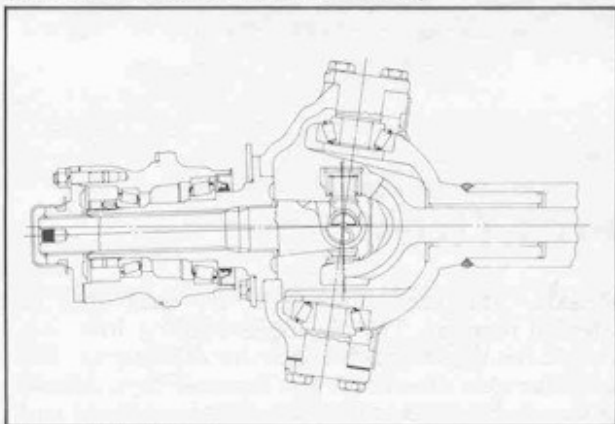


Figure L/D 5

1019-5

Remove wheel from drum assembly.

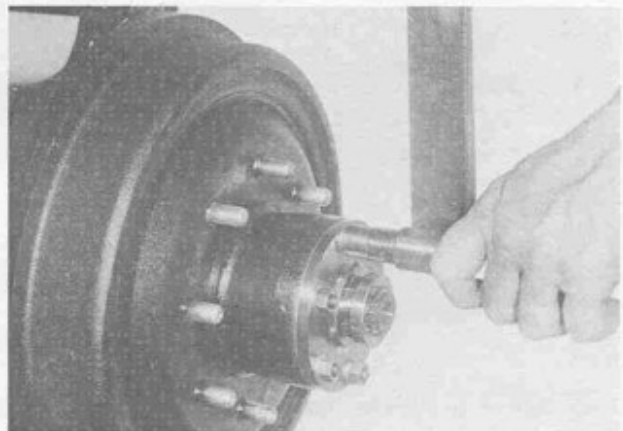


Figure 7

1019-7

Remove nuts and washers from drive flange studs.

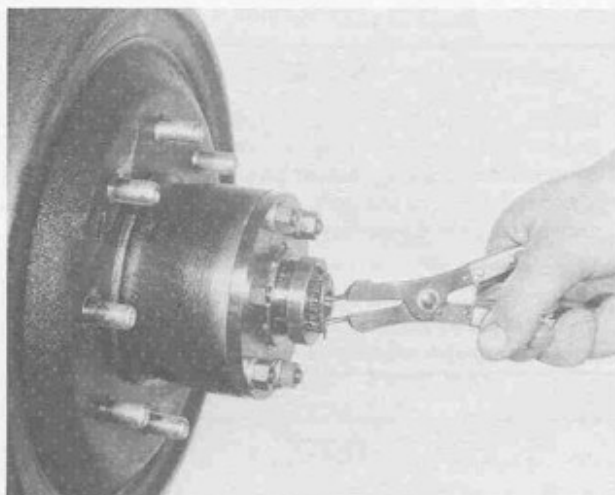


Figure 6

1019-6

Remove hub cap and snap ring.

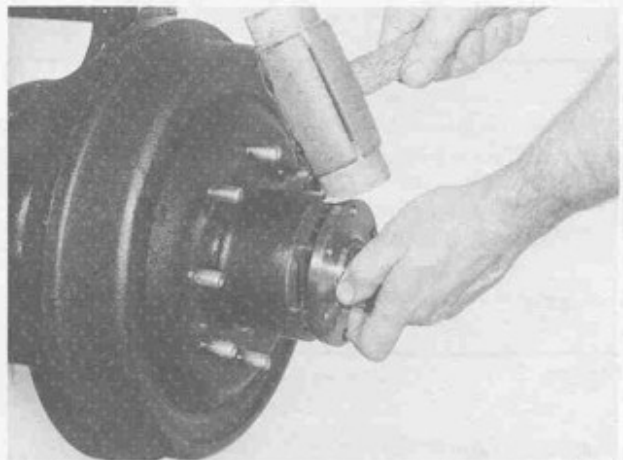
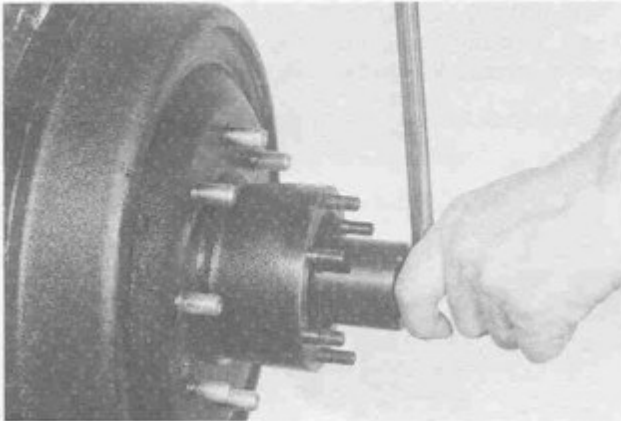


Figure 8

1019-8

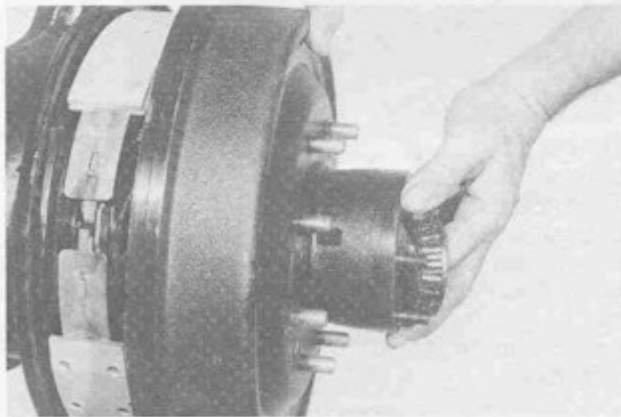
Remove drive flange and gasket. Discard gasket. Replace with new one at time of assembly. To free flange from hub, tap lightly with a rawhide hammer.

## FRONT AXLE



**Figure 9** 1019-9  
Remove outer locknut, lockring, and inner wheel bearing adjusting nut.

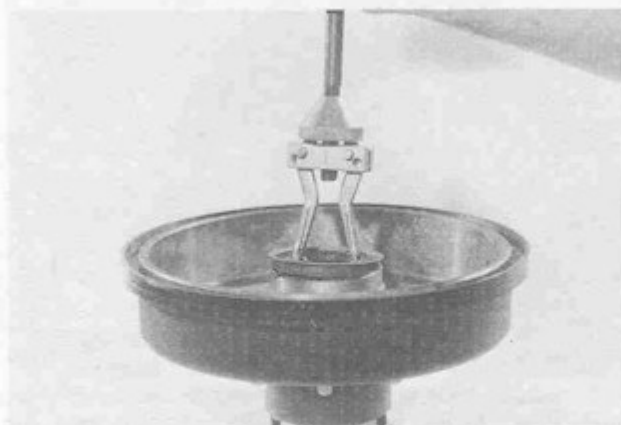
Tool: #C-4170 Wheel Wrench.



**Figure 10** 1019-10  
Remove drum assembly. Outer wheel bearing will slide out as drum is removed.

### NOTE

If it is necessary to replace brake components such as drums, shoes, backing plate, etc., refer to vehicle service manual.



**Figure 11** 1019-11

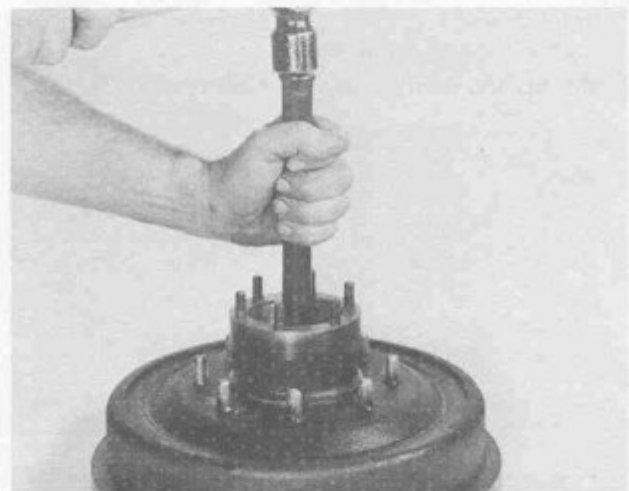
Remove grease seal and inner bearing cone. Discard seal and replace with new one at time of assembly.

Tool: #D-131 Slide Hammer.



**Figure 12** 1019-12  
Remove inner and outer wheel bearing cups.  
Tools: #D-255 Cup Remover, #C-4171 Handle.

## ASSEMBLY



**Figure 13** 1019-13  
Assemble outer wheel bearing cup.  
Tools: #C-4023 Installer, #C-4171 Handle.

## FRONT AXLE



**Figure 14**

1019-14

Assemble inner wheel bearing cup.

Tools: #D-111 Installer, #C-4171 Handle.

Distribute a sufficient amount of grease inside the hub between the bearing cups.

Pack inner bearing cone full with the specified grease. Wipe the excess grease around the rollers. Assemble inner wheel bearing cone into cup.

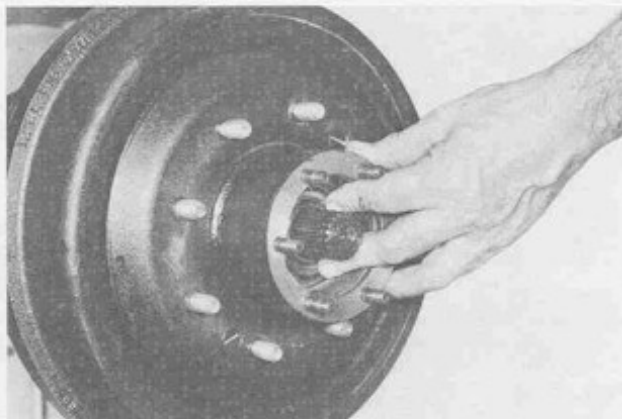


**Figure 15**

1019-15

Assemble new grease seal. Apply a small amount of grease around lip of seal.

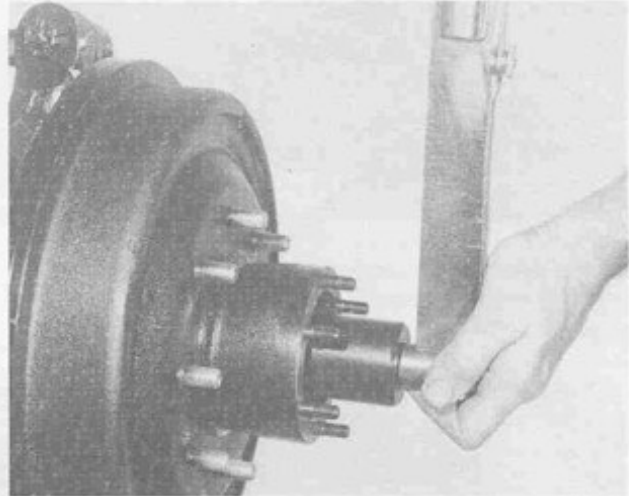
Tools: #D-155 Seal Installer, #C-4171 Handle.



**Figure 16**

1019-16

Assemble hub and drum onto spindle. Pack outer wheel bearing with specified grease, wipe excess grease around the rollers. Assemble onto spindle.

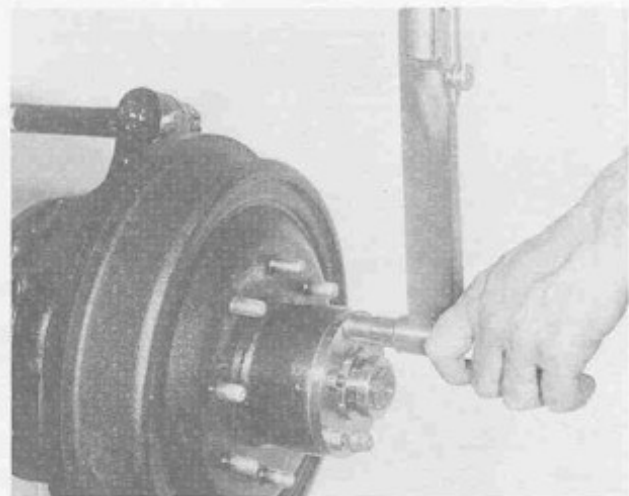


**Figure 17**

1019-17

To adjust wheel bearings, torque inner adjusting nut to 50 Lb. Ft. (68 N·m) to seat bearings. Rotate hub, then back off inner adjusting nut one fourth turn maximum. Assemble lock washer, turn nut to the nearest hole in washer. Assemble outer locknut and torque to 50 Lb. Ft. (68 N·m). Final bearings adjustment to be .001''-.010'' (.03-.25 mm) total end play.

Tools: #C-4170 Wheel Bearing Wrench, #C-524A Torque Wrench.



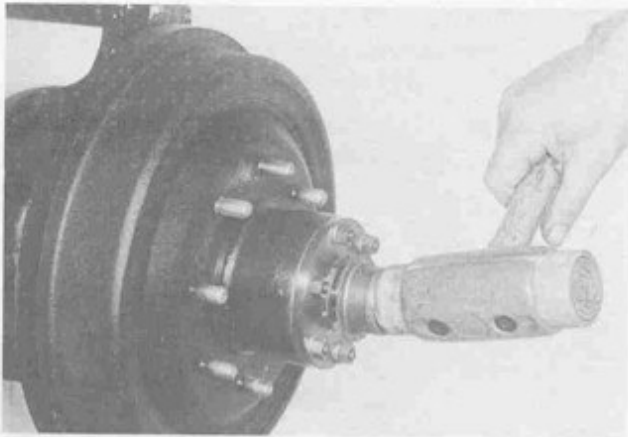
**Figure 18**

1019-18

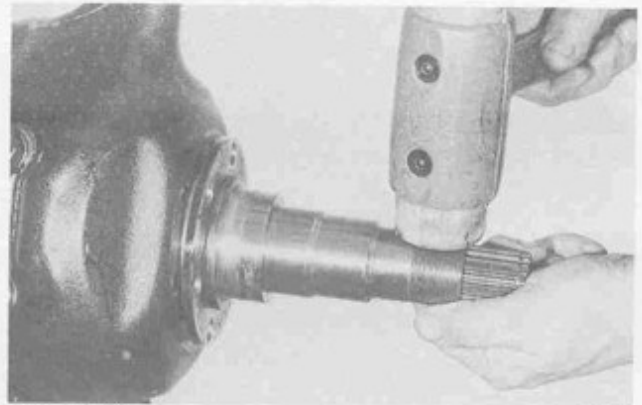
Assemble new gasket, drive flange, lockwashers, and nuts. Refer to Vehicle Service Manual for proper torque specifications.



## FRONT AXLE



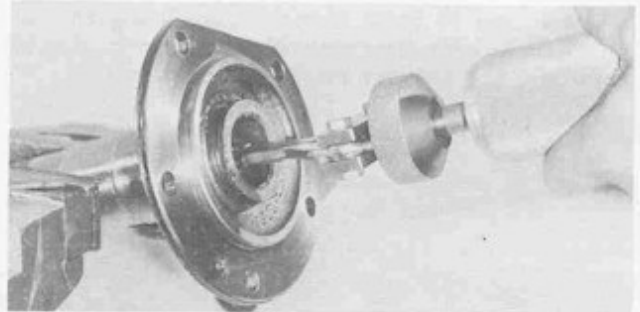
**Figure 19** 1019-19  
Assemble snap ring and hub cap. Tap lightly with hammer to seat hub cap.



**Figure 21** 1019-21  
Remove spindle. Tap lightly with a rawhide hammer to break the spindle loose from the knuckle.

### DISASSEMBLY AND REASSEMBLY OF SHAFTS, SPINDLE KNUCKLES, AND ETC., (CLOSED KNUCKLE DESIGN)

Remove wheel, hub and drum assembly as shown in Figure 6 thru 10.



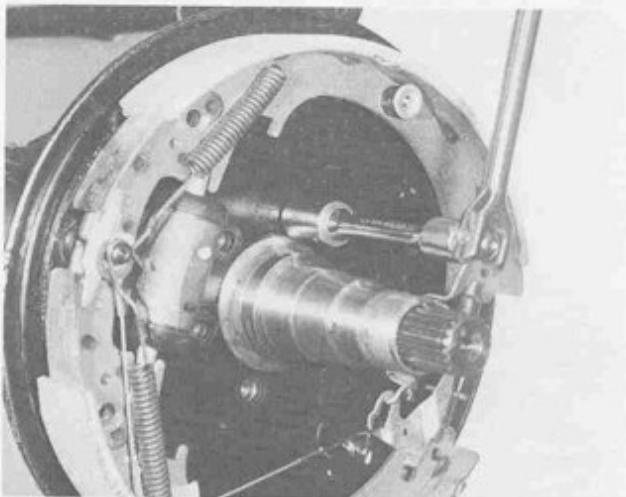
**Figure 22** 1019-22  
Place spindle in vise, do not locate on bearing diameters.

#### CAUTION

Be sure that the vise jaws are equipped with brass protectors or similar type to protect the machined surfaces of any parts that are to be placed in the vise.

Remove bronze bushing with slide hammer puller.

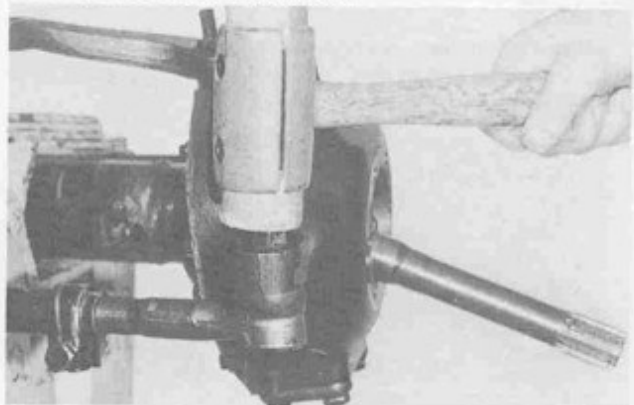
Tool: #D-131 Slide Hammer.



**Figure 20** 1019-20  
Remove backing plate screws and remove backing plate.

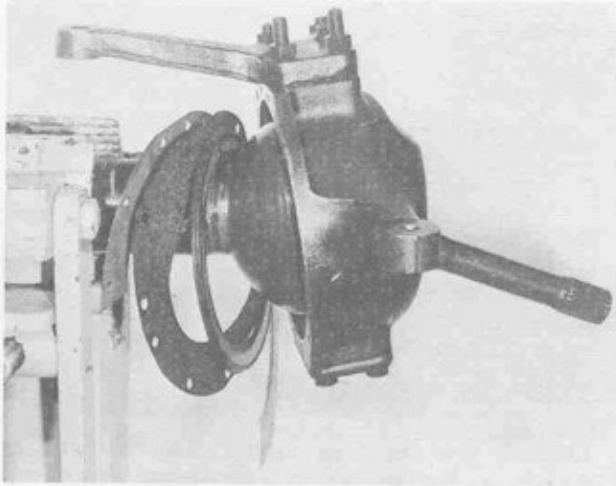
#### NOTE

The brake backing plate assembly can be retained with screws or nuts. If the nuts are of the torque prevailing design, they are to be replaced with new ones.

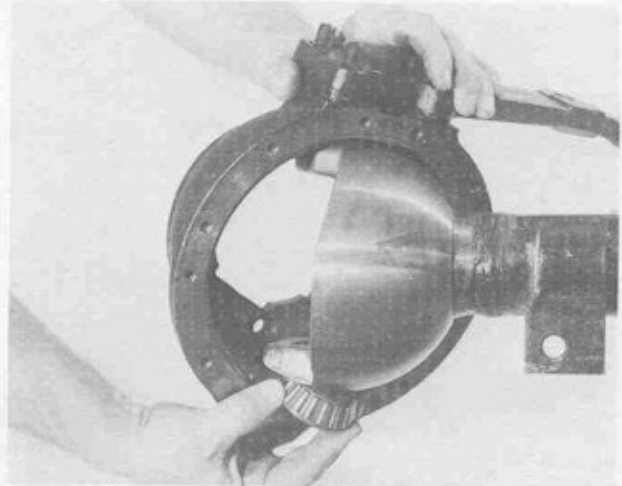


**Figure 23** 1019-23  
Remove cotter key and loosen tie rod nut. Tap on nut with rawhide hammer to break the stud loose from the steering arm. Remove nut and disconnect tie rod.

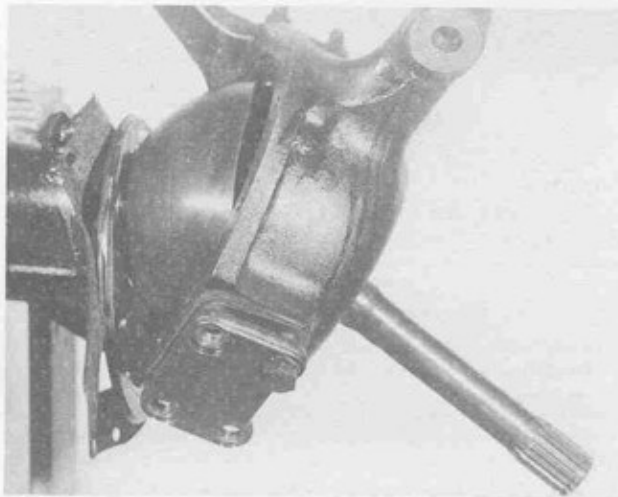
## FRONT AXLE



**Figure 24** 1019-24  
Remove twelve cap screws, two retainer plates, felt seal, and oil seal. Discard retainer plates, felt seal, and oil seal. Replace with new ones at time of assembly. Cut felt seal in half to disassemble.



**Figure 26** 1019-26  
Remove knuckle from ball yoke.



**Figure 25** 1019-25  
Remove four cap screws from the bottom bearing cap. Use a screwdriver to loosen the bearing cap from the knuckle if necessary.

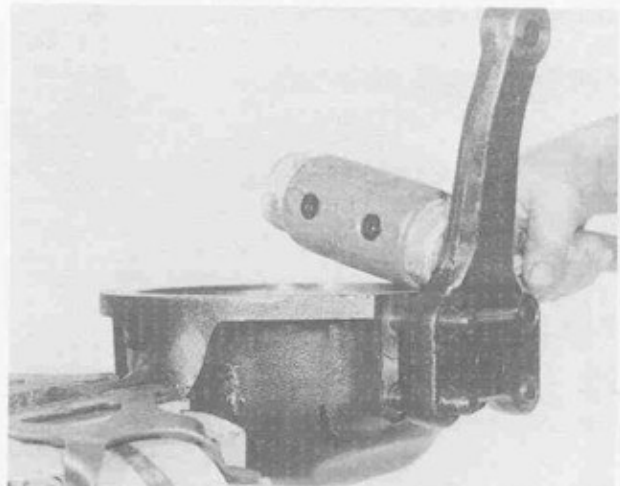
### NOTE

King pin bearing preload shims are located between the bottom bearing cap and knuckle. Wire shims together as they will be used during assembly. Shims may stick to either the knuckle or bearing cap. Be sure you have them all collected.

Shims are available in thicknesses of .003", .005", .010", and .030" (mm .08, .13, .25, and .76). Remove axle shaft joint assembly.

### CAUTION

The bottom bearing cone will fall out as the knuckle is being removed. To prevent damage to the bearing, catch it with hand.

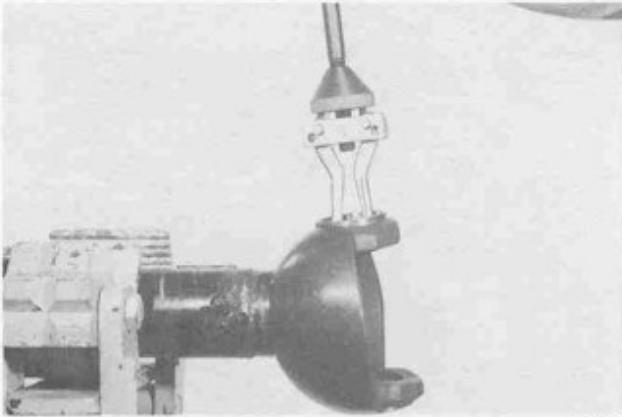


**Figure 27** 1019-27  
Place knuckle in vise as shown. Remove steering arm. Tap lightly with a rawhide hammer to free it from the knuckle.

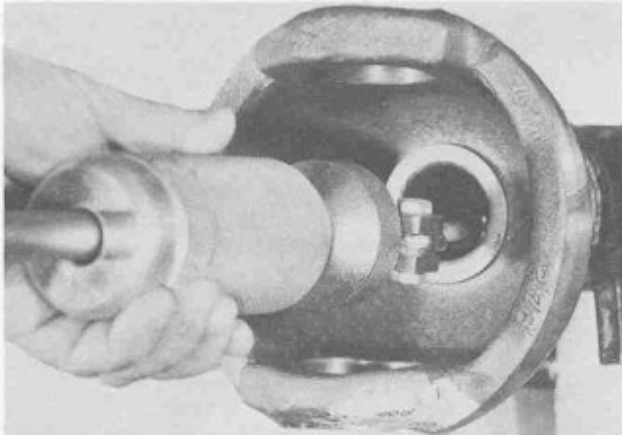
### NOTE

Some axles are equipped with a constant shim pack between the steering arm bearing cap and knuckle. If used, this pack is to be saved and reused during assembly.

## FRONT AXLE

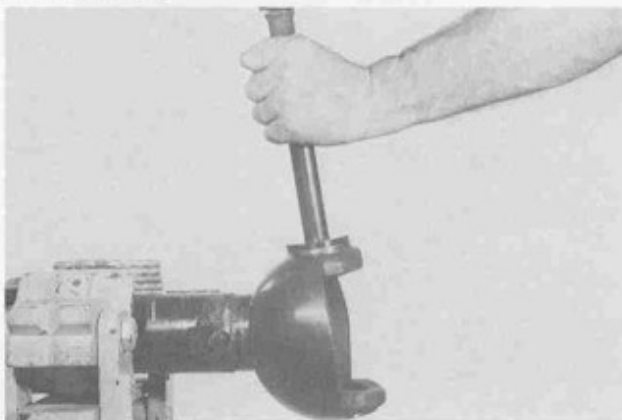


**Figure 28** 1019-28  
Remove king pin bearing cups from spherical ball yoke, with tool as shown.  
Tool: #D-131 Slide Hammer.



**Figure 29** 1019-29  
Remove bronze bushing from ball yoke.  
Tool: #D-131 Slide Hammer.

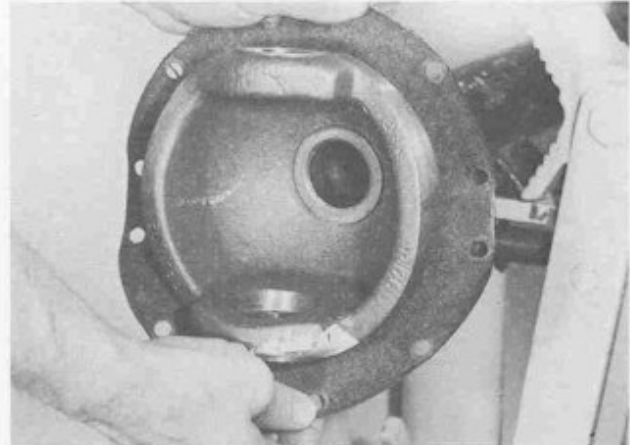
### ASSEMBLY



**Figure 30** 1019-30  
Assemble new king pin bearing cups into spherical ball yoke. Use tools as shown.  
Tools: #D-142 Installer, #C-4171 Handle.



**Figure 31** 1019-31  
Assemble new bronze bushing into ball yoke.  
Tools: #D-161 Installer, #C-4171 Handle.

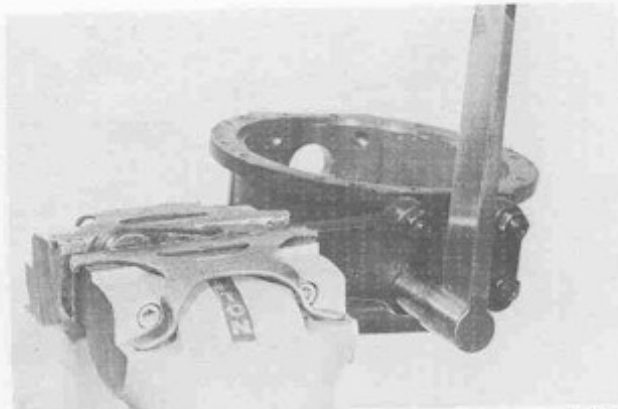


**Figure 32** 1019-32  
Assemble new felt over spherical ball as shown.



**Figure 33** 1019-33  
Assemble new oil seal with the metal part of the seal towards the end of the axle. Spread split of seal just enough to slip over the tube of the axle.

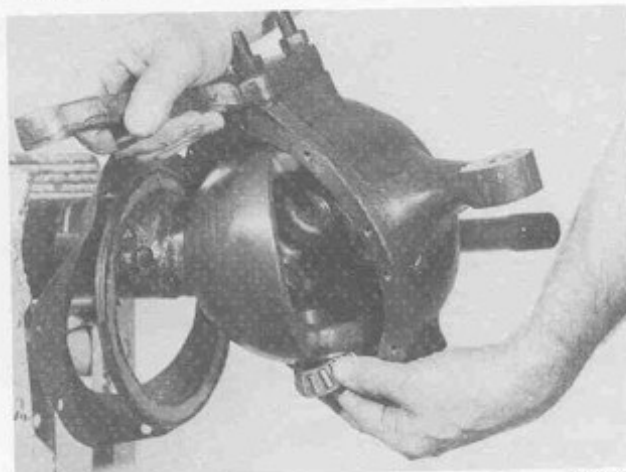
## FRONT AXLE



**Figure 34**

1019-34

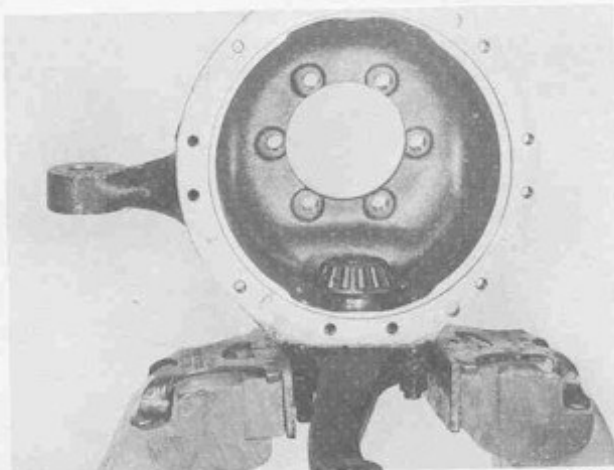
Locate steering arm in vise as shown. Assemble constant shim pack to the knuckle (if used). Assemble knuckle to the steering arm. Assemble the four nuts, tighten nuts alternately and evenly. Torque nuts to 70-90 Lb. Ft. (95-122 N·m).



**Figure 37**

1019-37

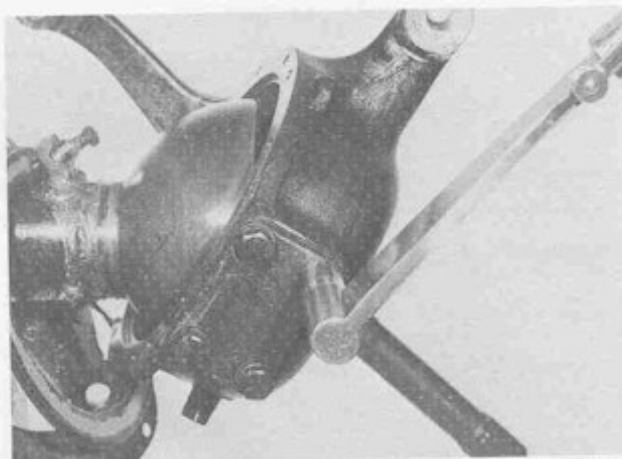
Assemble knuckle to ball yoke. Hold bottom bearing (new) as shown to prevent it from falling out.



**Figure 35**

1019-35

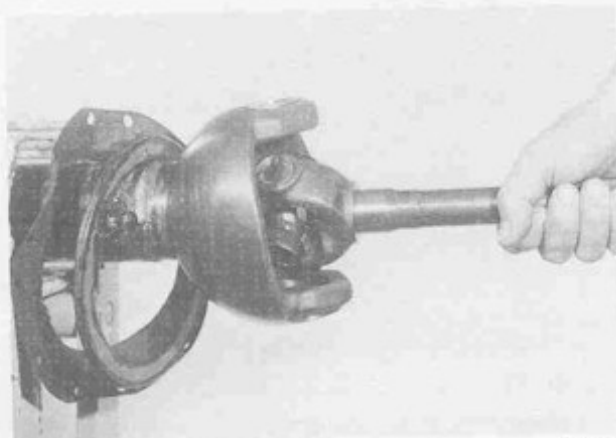
Assemble new bearing cone to king pin, grease bearing with specified grease.



**Figure 38**

1019-38

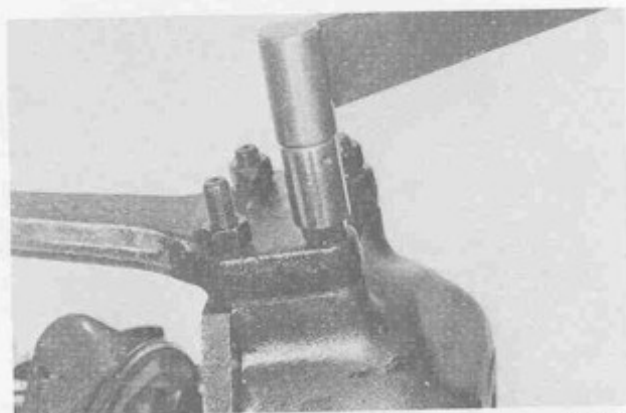
Assemble bottom king pin bearing cap, with preload shims, and four cap screws. Torque screws to 70-90 Lb. Ft. (95-122 N·m).



**Figure 36**

1019-36

Assemble axle shaft joint assembly into housing.



**Figure 39**

1019-39

Place a torque wrench on steering arm nut as shown. Torque to actuate knuckle to 9-15 Lb. Ft. (12-20 N·m). When checking torque rotation of knuckle, make sure tie rod and seals are not assembled to knuckle.

## FRONT AXLE

### NOTE

If preload is too tight, correct by adding shims. If preload is too loose, correct by removing shims. Preload shim pack is located on the bottom between the bearing cap and knuckle. Shims are available in thicknesses of .003", .005", .010", and .030" (mm .08, .13, .25, and .76).

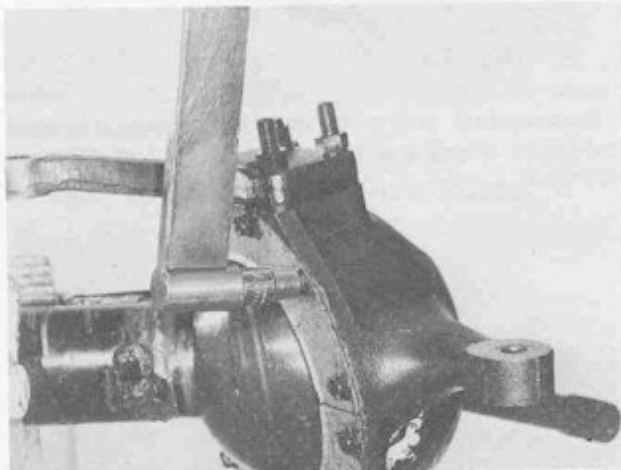


Figure 40

1019-40

Assemble new oil seal into knuckle. Be sure split of seal is to the top of the axle. Assemble new felt, two retainer plates and twelve cap screws. Torque screws to 15 Lb. Ft. (20 N·m).

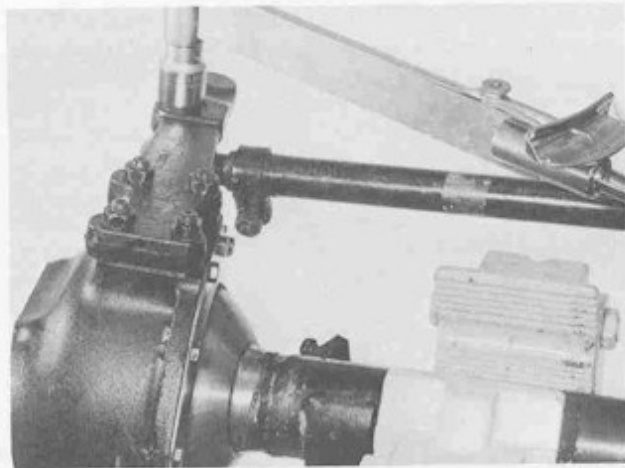


Figure 41

1019-41

Assemble tie rod to steering arm for specified torque on tie rod nut, refer to Vehicle Service Manual. Assemble cotter key.

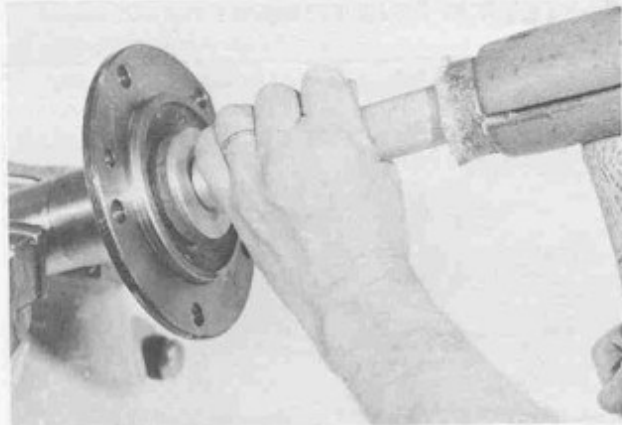


Figure 42

1019-42

Position spindle in vise as shown and assemble new bushing. Grease inside of bushing with specified grease.

Tools: #D-141 Installer, #C-4171 Handle.

Assemble spindle to knuckle.

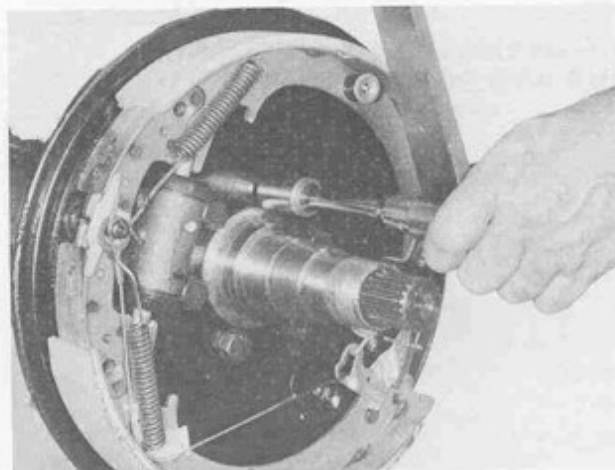


Figure 43

1019-43

Assemble brake backing plate assembly. Refer to Vehicle Service Manual for specified screw torque.

Remove inspection plug from knuckle and fill level to the plug hole with specified lubricant. Assemble inspection plug.

### NOTE

To set toe-in refer to Vehicle Service Manual. Adjustments can be made by loosening clamps on the tie rod. After proper adjustments are made, retighten tie rod clamps.

# FRONT AXLE

## 40° STEER SPRING LOADED

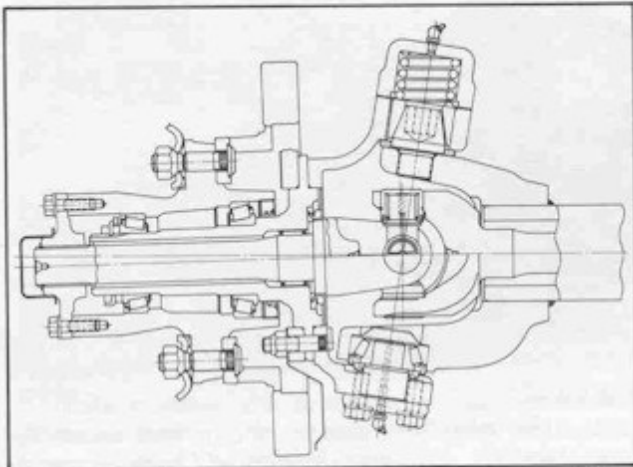


Figure 44 L/D

1019-44

## DISASSEMBLY OF WHEEL ENDS - HUB AND ROTOR

### NOTE

If it is necessary to replace brake components such as disc brake pads, backing plate, etc., refer to Vehicle Service Manual.

Remove Wheel from Hub and Rotor Assembly.

Follow the vehicle manufacturers recommendations for the removal of the hub-lok assembly, if used.

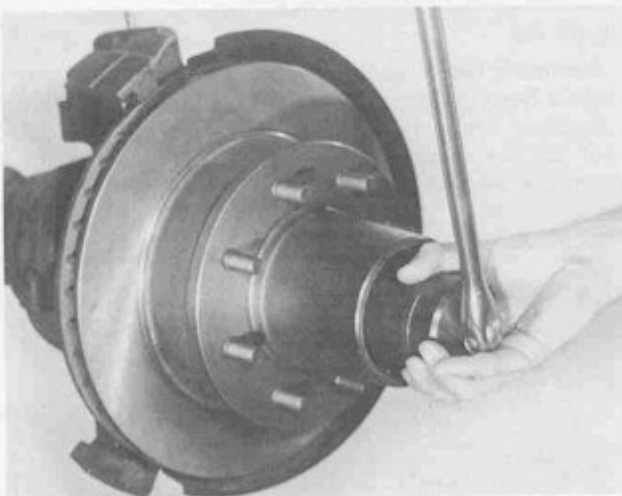


Figure 45

1019-45

Remove wheel bearing lock nut, lock ring and the wheel bearing adjusting nut.

Tool: #D-165A Wheel Bearing Wrench.



Figure 46

1019-46

Remove hub and rotor assembly, spring retainer and outer wheel bearing will slide out as rotor is removed.

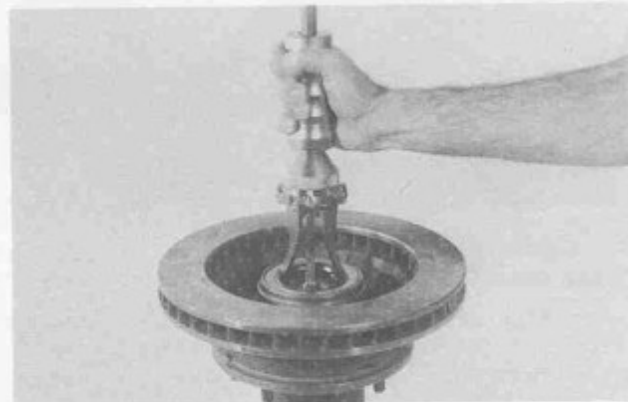


Figure 47

1019-47

Remove grease seal and inner bearing cone. Discard seal and replace with new one at time of assembly.

Tool: #D-131 Slide Hammer.



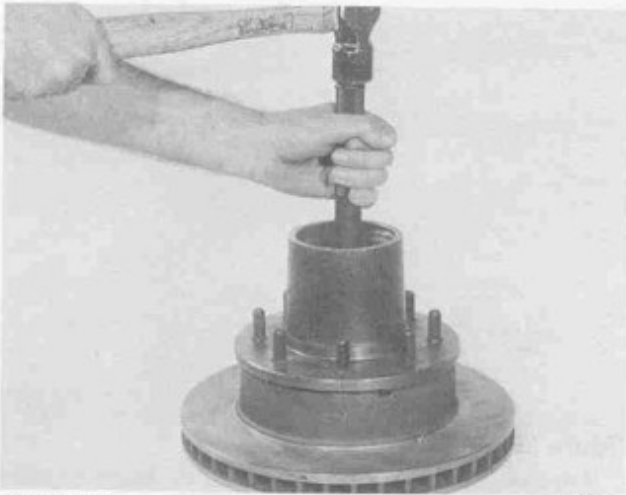
Figure 48

1019-48

Remove inner and outer wheel bearing cups.

Tools: #D-255 Bearing Cup Remover (outer).  
#D-257 Bearing Cup Remover (inner).

# FRONT AXLE



**Figure 49** 1019-49  
Assemble outer wheel bearing cup.  
Tools: #D-254 Installer, #C-4171 Handle.



**Figure 50** 1019-50  
Assemble inner wheel bearing cup.  
Tools: #D-256 Installer, #C-4171 Handle.

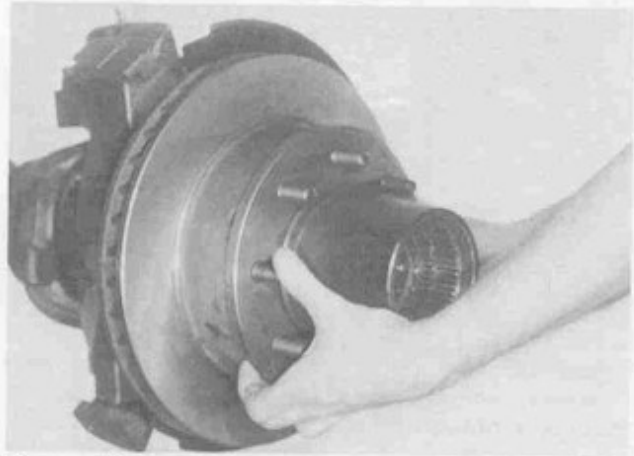
Distribute a sufficient amount of grease inside the hub between the bearing cups. Pack inner bearing cone full with the specified grease. Wipe the excess grease around the rollers. Assemble inner wheel bearing cone into cup.



**Figure 51** 1019-51

Assemble new grease seal. Apply a small amount of grease around lip of seal.

Tools: #D-253 Seal Installer, #C-4171 Handle.



**Figure 52** 1019-52  
Assemble hub and rotor onto spindle. Pack outer wheel bearing with specified grease, wipe excess grease around the rollers. Assemble onto spindle.



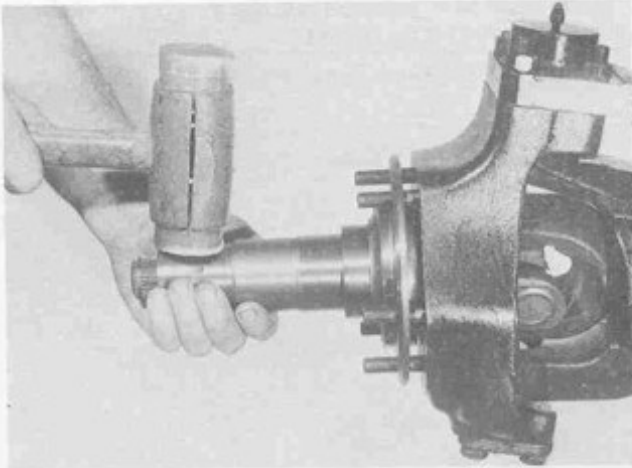
**Figure 53** 1019-53  
To adjust wheel bearings, torque inner adjusting nut to 50 Lb. Ft. (68 N·m) to seat bearings. Rotate hub, then back off inner adjusting nut one-fourth turn maximum. Assemble lock washer, turn nut to nearest hole in washer. Assemble outer locknut and torque to 50 Lb. Ft. (68 N·m). Final bearings adjustment to be .001-.010 (.03-.25 mm) total end play.

Tools: #D-165A Wheel Bearing Wrench, #C-512A Torque Wrench.

## NOTE

For servicing spindle and knuckle, remove hub and drum as described in figures 45 through 47.

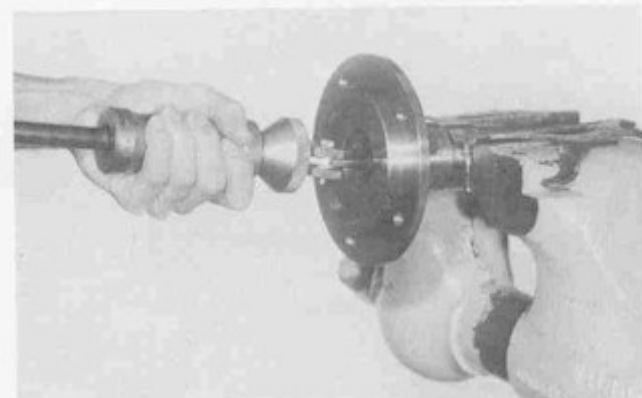
## FRONT AXLE



**Figure 54**

1019-54

Remove spindle. If necessary, tap lightly with a rawhide hammer to free it from the knuckle. Check bronze spacer located between axle shaft joint assembly and bearing. If wear is evident, replace with a new one.



**Figure 55**

1019-55

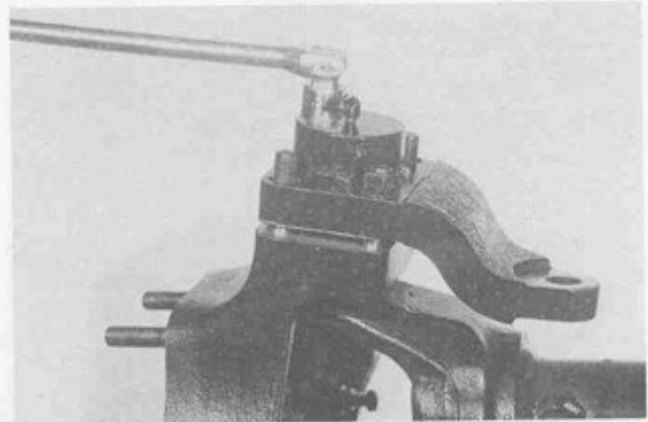
Place spindle in vise. Do not locate on bearing diameters. Remove needle bearing.

Tool: #D-131 Slide Hammer.

### CAUTION

Be sure that vise jaws are equipped with brass protectors or similar type to protect the machined surfaces of any parts that are to be placed in the vise.

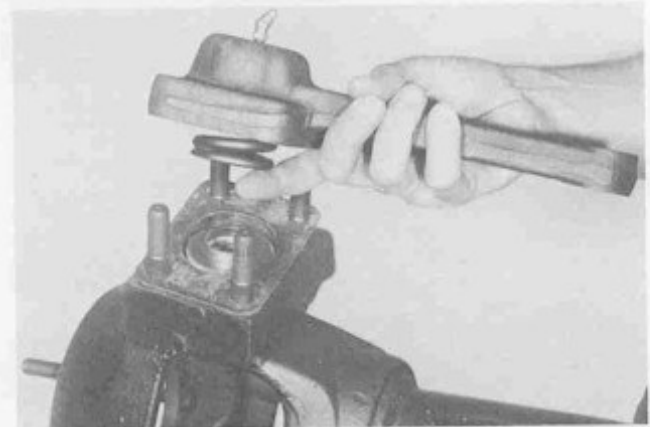
Remove axle shaft joint assembly. Remove tie rod. Refer to Figure 23.



**Figure 56**

1019-56

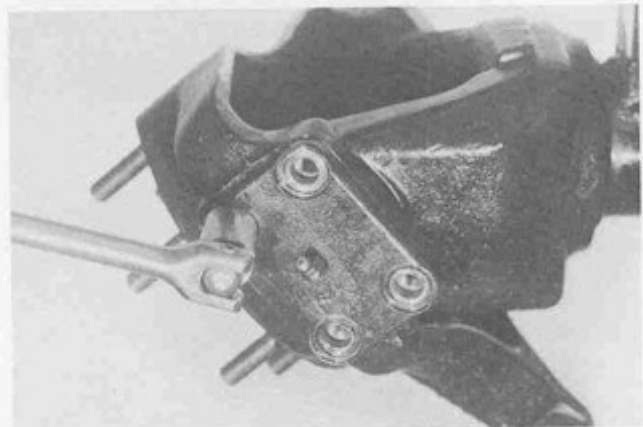
Remove four nuts on steering arm. Remove nuts alternately as compression spring will force steering arm up.



**Figure 57**

1019-57

Remove steering arm, compression spring, and gasket. Discard gasket, replace with new one at time of assembly.



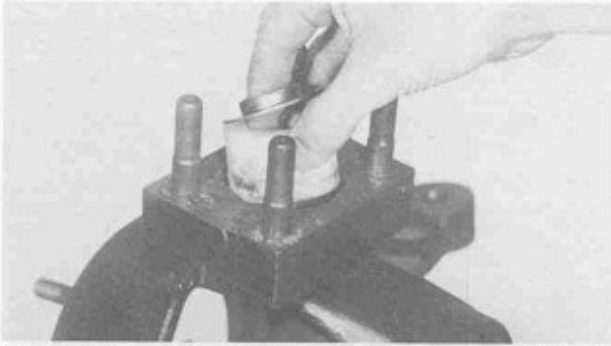
**Figure 58**

1019-58

Remove four cap screws on bearing cap. Remove bearing cap.



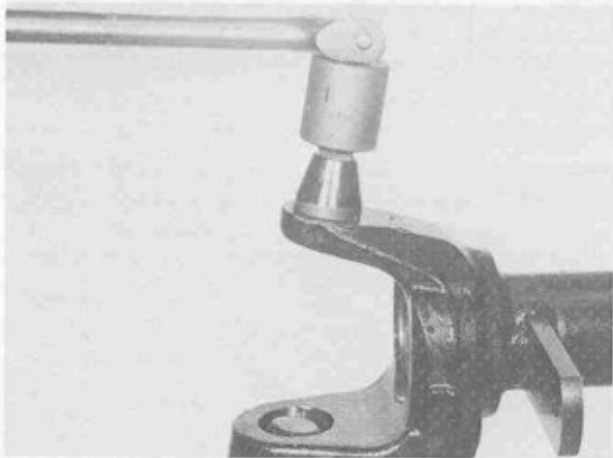
## FRONT AXLE



**Figure 59**

1019-59

Remove king pin tapered bushing, spring retainer, and knuckle from yoke. Remove king pin seal.



**Figure 60**

1019-60

Remove king pin as shown.

Tool: #D-192 King Pin Installer and Remover.



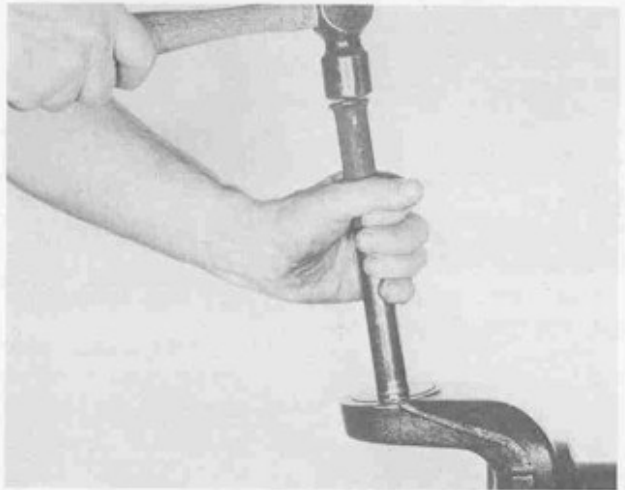
**Figure 61**

1019-61

Remove king pin bearing cup, cone, grease retainer, and seal all at the same time. Assemble and use tools exactly as shown in Figure 62. Discard seal and replace with new one at time of assembly. If grease retainer is damaged, replace with new one at time of assembly.

Tools: #D-141 Installer, #C-4171 Handle.

## ASSEMBLY



**Figure 62**

1019-62

Assemble new grease retainer and king pin bearing cup.

Tools: #D-142 Installer, #C-4171 Handle.



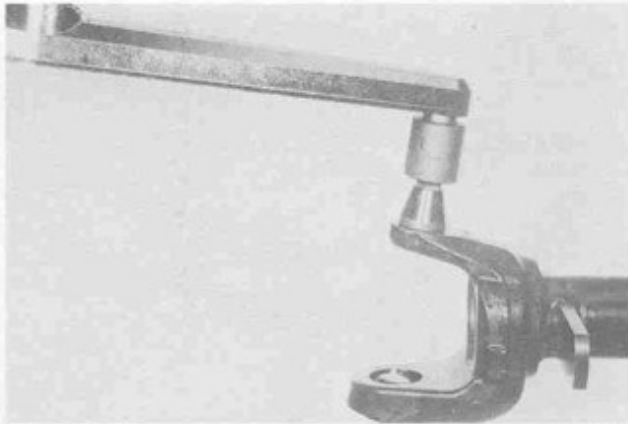
**Figure 63**

1019-63

Fill the area in grease retainer with specified grease, grease bearing cone and install. Install new king pin bearing oil seal.

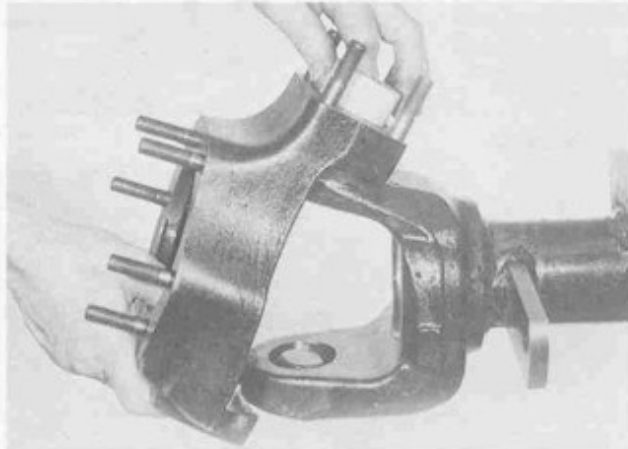
Tools: #D-194 Installer, #C-4171 Handle.

## FRONT AXLE

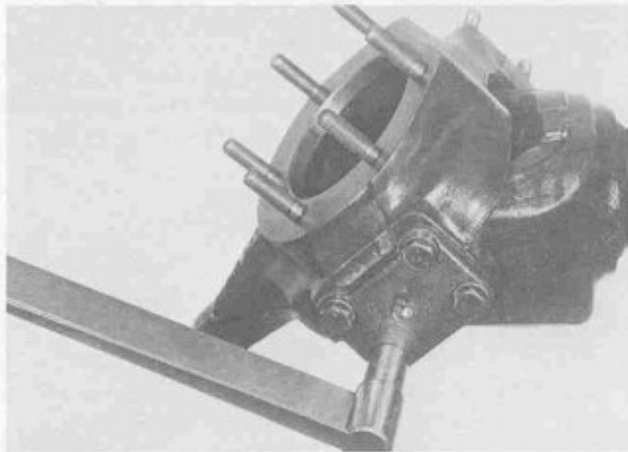


**Figure 64** 1019-64  
Install king pin. Torque king pin to 500-600 Lb. Ft. (678-813 N·m).

Tools: #D-192 King Pin Installer and Remover, #DD-994 Torque Wrench.

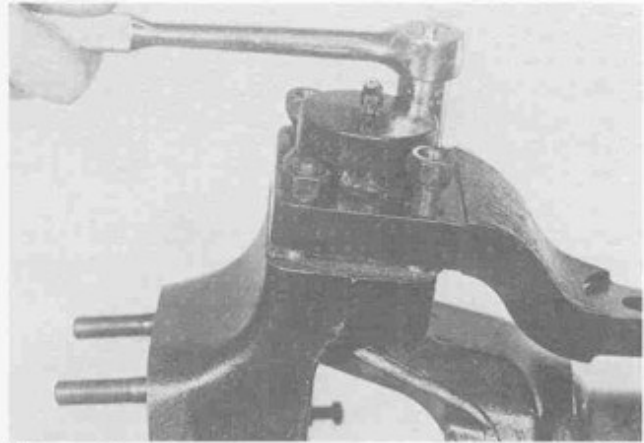


**Figure 65** 1019-65  
Assemble felt seal to king pin, assemble knuckle assemble tapered bushing over king pin.

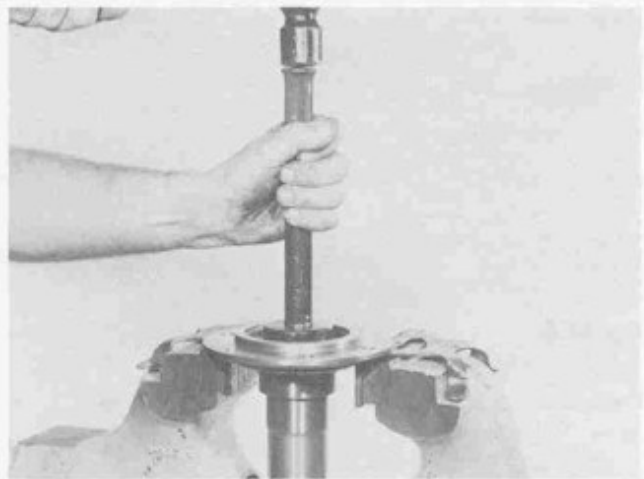


**Figure 66** 1019-66  
Assemble bearing cap with four cap screws. Tighten cap screws alternately and evenly. Torque cap screws to 70-90 Lb. Ft. (95-122 N·m).

Tool: #C-524-A Torque Wrench.



**Figure 67** 1019-67  
Assemble spring retainer and compression spring on king pin bushing. Assemble steering arm, with new gasket, over four studs. Tighten nuts alternately and evenly. Torque nuts 70-90 Lb. Ft. (95-122 N·m).

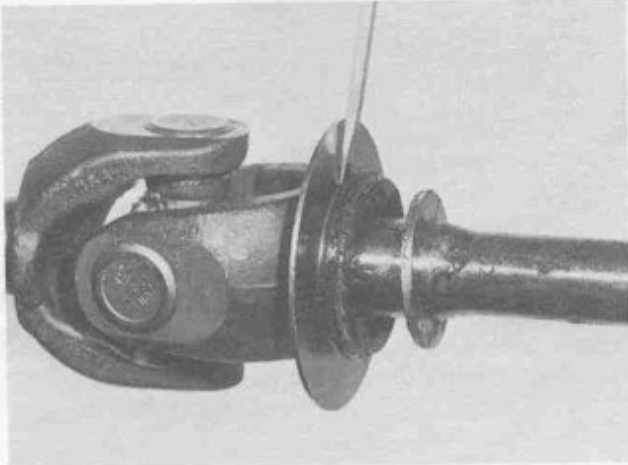


**Figure 68** 1019-68  
Assemble new needle bearing into spindle.  
Tools: #D-258 Installer, #C-4171 Handle.



**Figure 69** 1019-69  
Assemble grease seal into spindle. The lip of the seal is to be directed away from the spindle.

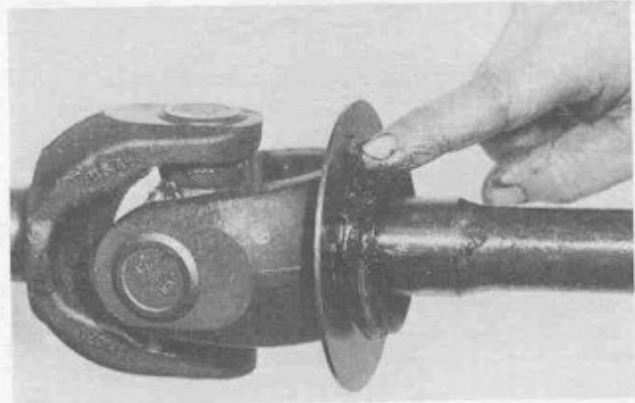
# FRONT AXLE



**Figure 70**

1019-70

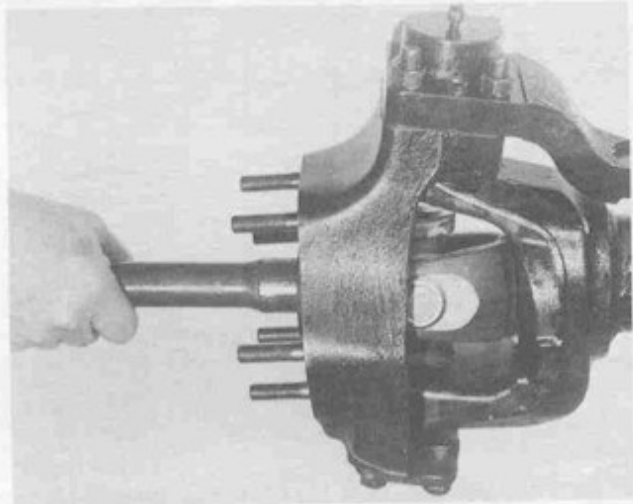
Some front axles are equipped with a "V" seal, which is assembled to the axle shaft stone shield as shown. If seal is worn, remove and replace with a new one.



**Figure 72**

1019-72

Pack the area around the thrust face area of the shaft and seal full of grease. Also, fill the seal area of the spindle with grease.



**Figure 73**

1019-73

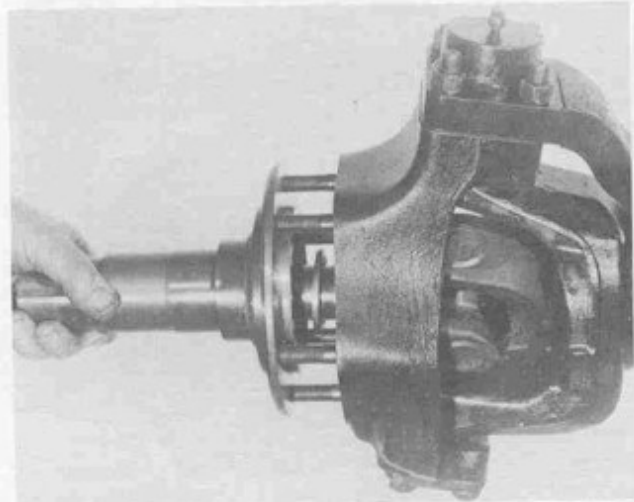
Assemble axle shaft joint assembly into housing.



**Figure 71**

1019-71

Assemble new seal as shown. Lip of the seal is to be directed towards the spindle.



**Figure 74**

1019-74

Assemble new bronze spacer and spindle.